

UC CACC CM 2U

19" 2U cable management, Plastic light weight, Compact - 2.5 inch

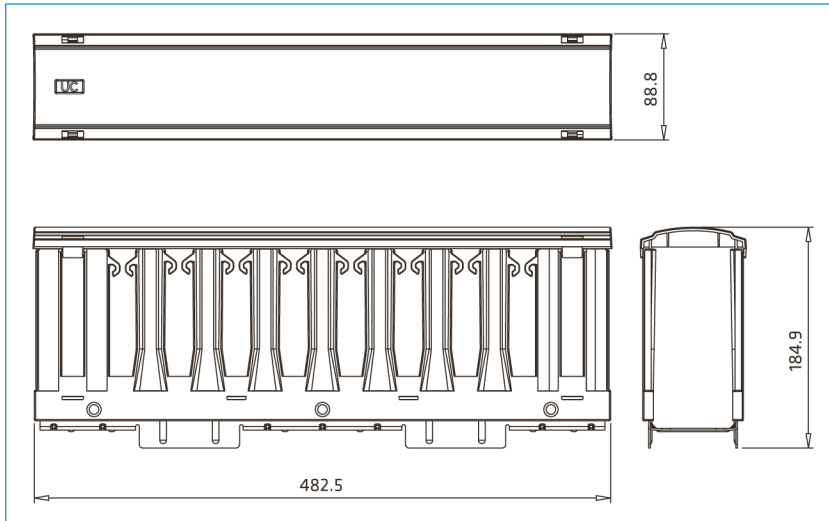

- 2U Horizontal Cable Management.
- Hinged Front cover provides easy way to access and manage the patch cords.
- Complies with ANSI/TIA/EIA-310-D Cabinets, Racks, Panels and Associated Equipment.
- Horizontal mountable design can be used as horizontal cable management as well.
- High Capacity Cable duct design.

Ordering Information

SAP IC	UC P/N	UC Material Code	Product Description	P.U
YCMBP00350	CM2U9850	UC CACC CM 2U	19" 2U cable management, Plastic light weight, Compact - 2.5 inch	1pc/box